

# PRODUCT INFORMATION PACKET

Model No: TCA0223A3131GACD01

Catalog No: TCA0223A3131GACD01

22.0 kW General Purpose Low Voltage IEC Motor, 3 phase, 1000 RPM, 415 V, 200L Frame, TEFC  
Cast Iron IE3 Efficiency Motors





### Nameplate Specifications

Output HP	30 Hp	Output KW	22.0 kW
Frequency	50 Hz	Voltage	415 V
Current	42.0 A	Speed	987 rpm
Service Factor	1	Phase	3
Efficiency	92.2 %	Power Factor	0.79
Duty	S1	Insulation Class	F
Frame	200L	Enclosure	Totally Enclosed Fan Cooled
Ambient Temperature	50 °C	Drive End Bearing Size	6312
Opp Drive End Bearing Size	6212	UL	No
CSA	No	CE	Yes
IP Code	55		

### Technical Specifications

Electrical Type	Squirrel Cage	Starting Method	Direct On Line
Poles	6	Rotation	Bi-Directional
Mounting	B35	Motor Orientation	Horizontal
Drive End Bearing	C3	Opp Drive End Bearing	C3
Frame Material	Cast Iron	Shaft Type	Keyed
Overall Length	769 mm	Frame Length	370 mm
Shaft Diameter	55 mm	Shaft Extension	110 mm
Assembly/Box Mounting	Top		
Connection Drawing	8442000085	Outline Drawing	0220000343

This is an uncontrolled document once printed or downloaded and is subject to change without notice. Date Created:06/01/2020

# OUTLINE

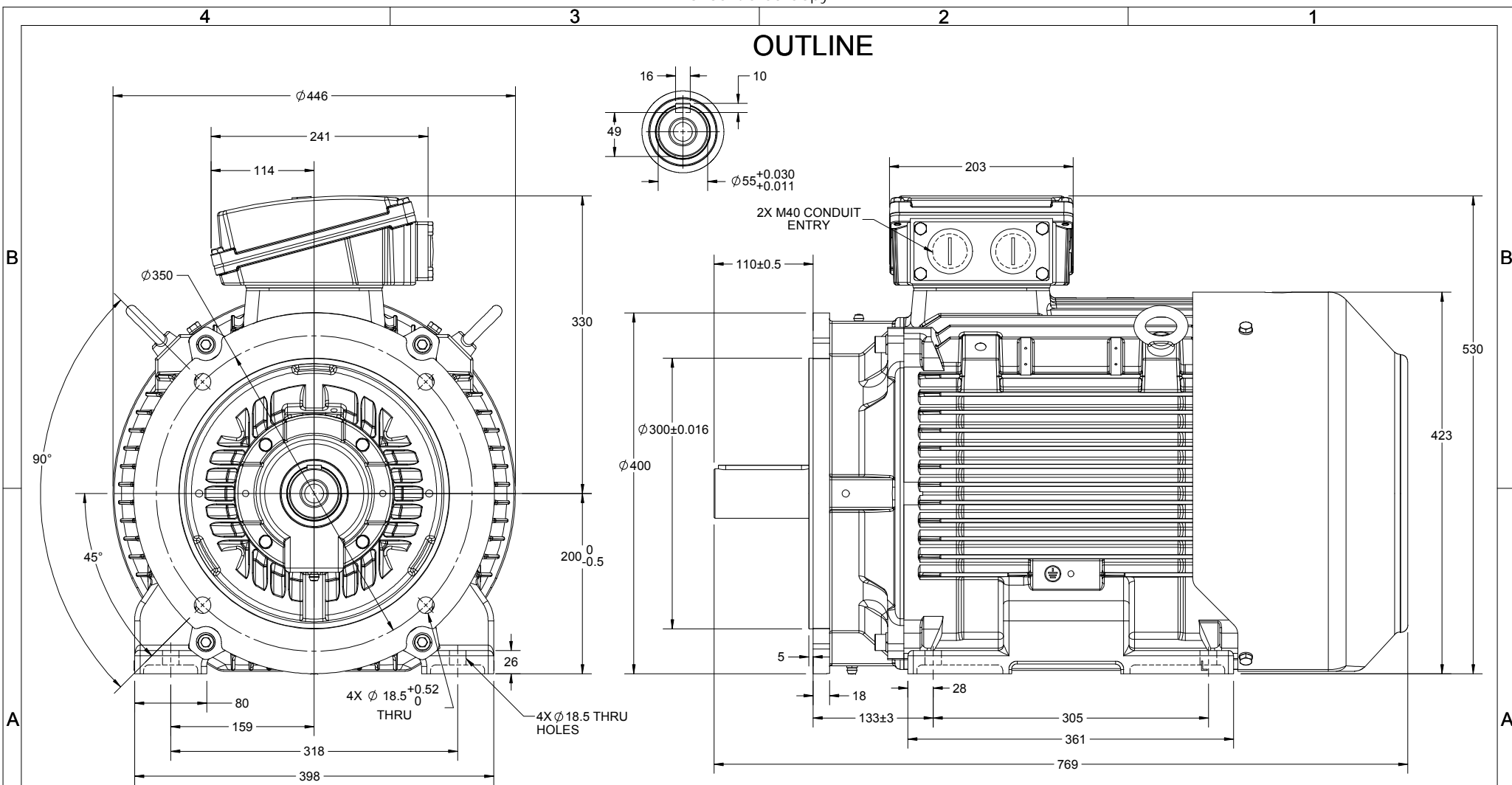

DRAWING REVISION C	REVISION BY NIV	DATE 26/04/2019
ECO ECO-0165600	APPROVED BY SR	DATE 26/04/2019
ECO DESCRIPTION MODEL UPDATED		
<small>COPYRIGHT REGAL BELOIT AMERICA, INC. ALL RIGHTS RESERVED.          PROPRIETARY AND CONFIDENTIAL INFORMATION - THIS DOCUMENT IS THE PROPERTY OF          REGAL BELOIT AMERICA, INC. (OWNER) AND CONTAINS OWNERS PROPRIETARY          INFORMATION. ANY PERSON, CORPORATION OR OTHER FIRM RECEIVING IT IS DEEMED,          BY RECEIVING IT, TO AGREE THAT IT, AND/OR ANY PART OF IT, SHALL NOT BE DISCLOSED          TO ANY PERSON, CORPORATION OR OTHER ENTITY, DUPLICATED, AND/OR USED, EXCEPT          AS EXPRESSLY APPROVED IN WRITING IN ADVANCE BY OWNER. THIS DOCUMENT SHALL          BE RETURNED TO OWNER UPON REQUEST. IT MAY BE SUBJECT TO CERTAIN          RESTRICTIONS UNDER APPLICABLE EXPORT CONTROL LAWS AND REGULATIONS.</small>		

DRAWN BY SDV		DESCRIPTION <b>OUTLINE</b> 200FR-B35 MTG. MOTOR TYPE: TCA	
DATE 03/07/2014			
APPROVED BY SBD			
DATE 03/07/2014			
REFERENCE	MATERIAL	PROCESS/FINISH	
THIRD ANGLE PROJECTION	SIZE B	DRAWING NUMBER 0220000343	SHEET 1 OF 1

COPYRIGHT REGAL BELOIT AMERICA, INC. ALL RIGHTS RESERVED. This is an Unapproved Copy  
 PROPRIETARY AND CONFIDENTIAL INFORMATION - THIS DOCUMENT IS THE PROPERTY OF  
 REGAL BELOIT AMERICA, INC. ("OWNER") AND CONTAINS OWNER'S PROPRIETARY  
 INFORMATION. ANY PERSON, CORPORATION OR OTHER FIRM RECEIVING IT IS DEEMED  
 BY RECEIVING IT TO AGREE THAT IT AND/OR ANY PART OF IT SHALL NOT BE DISCLOSED  
 TO ANY PERSON, CORPORATION OR OTHER ENTITY, DUPLICATED, AND/OR USED, EXCEPT  
 AS EXPRESSLY APPROVED IN WRITING IN ADVANCE BY OWNER. THIS DOCUMENT SHALL  
 BE RETURNED TO OWNER UPON REQUEST. IT MAY BE SUBJECT TO CERTAIN  
 RESTRICTIONS UNDER APPLICABLE EXPORT CONTROL LAWS AND REGULATIONS.

DRAWING REVISION	REVISION BY	DATE
A	SN	13/01/2017
ECO-0116390	APPROVED BY SBD	DATE 13/01/2017
ECO DESCRIPTION NEW DRAWING RELEASE		

GEOMETRIC TOLERANCE		
LINEAR DIM	>0-6	±0.1
	>6-30	±0.2
	>30-120	±0.3

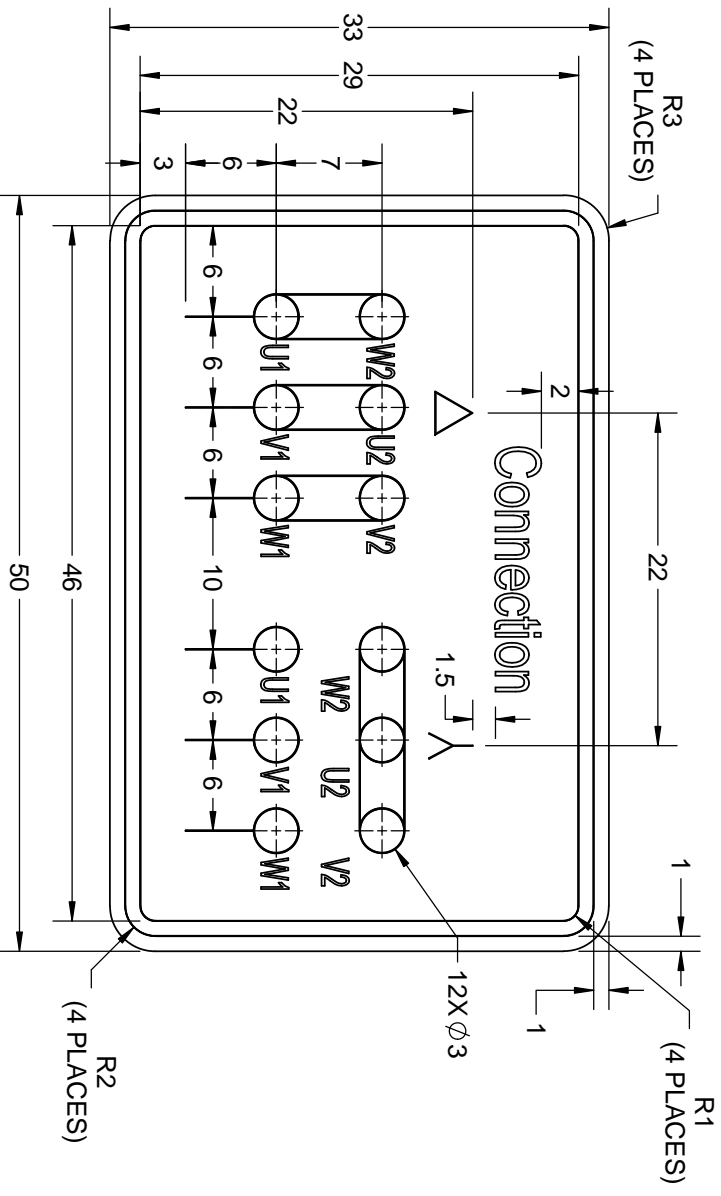

- NOTES:
1. PRESSURE-SENSITIVE ADHESIVE COATED PAPER ON THE BACK OF SELF-ADHESIVE.
  2. AT THE END OF YELLOW, WORDS, SYMBOLS, LETTERS ARE BLACK, BORDER IS BLACK.
  3. THE TOLERANCE OF THE LINEAR SIZE OF THE TOLERANCE WITHOUT THE TOLERANCE BY THE TABLE.

8WD.442.2017

DRAWN BY SN		 Regal Beloit America, Inc.	
DATE 16/12/2016			
APPROVED BY SBD		DESCRIPTION <b>CONN DIAGRAM-NAMEPLATE</b>	
DATE 16/12/2016			
REFERENCE		MATERIAL	
THIRD ANGLE PROJECTION		SIZE A	DRAWING NUMBER 8442000085
		PROCESS/FINISH	
		SHEET 1 OF 1	

Model No. TCA0223A3131GACD01

U (V)	Δ / Y Conn	f (Hz)	P		I [A]	n [RPM]	T [Nm]	IE Class	% EFF at __ load				PF at __ load			I <sub>a</sub> /I <sub>N</sub> [pu]	T <sub>b</sub> /T <sub>N</sub> [pu]	T <sub>v</sub> /T <sub>N</sub> [pu]
			[kW]	[hp]					5/4FL	FL	3/4FL	1/2FL	FL	3/4FL	1/2FL			
415	Δ	50	22	30	42.0	987	216.43	IE3	-	92.2	92.2	92.4	0.79	0.73	0.6	7.1	2.6	3.0

Motor type	TCA	Degree of protection	IP 55
Enclosure	TEFC	Mounting type	IM B35
Frame Material	Cast Iron	Cooling method	IC 411
Frame size	200L	Motor weight - approx.	329 kg
Duty	S1	Gross weight - approx.	359 kg
Voltage variation *	± 10%	Motor inertia	0.7703 kgm <sup>2</sup>
Frequency variation *	± 5%	Load inertia	Customer to Provide
Combined variation *	10%	Vibration level	2.2 mm/s
Design	N	Noise level ( 1meter distance from motor)	62 dB(A)
Service factor	1.0	No. of starts hot/cold/Equally spread	2/3/4
Insulation class	F	Starting method	DOL
Ambient temperature	-20 to +50 °C	Type of coupling	Direct
Temperature rise (by resistance)	70 [ Class B ] K	LR withstand time (hot/cold)	15/30 s
Altitude above sea level	1000 meter	Direction of rotation	Bi-directional
Hazardous area classification	NA	Standard rotation	Clockwise form DE
Zone classification	NA	Paint shade	RAL 5014
Gas group	NA	Accessories	
Temperature class	NA	Accessory - 1	-
Rotor type	Aluminum Die cast	Accessory - 2	-
Bearing type	Anti-friction ball bearing	Accessory - 3	-
DE / NDE bearing	6312 C3 / 6212 C3	Terminal box position	TOP
Lubrication method	Regreasable	Maximum cable size/conduit size	1R x 3C x 50mm <sup>2</sup> /2 x M40 x 1.5
Type of grease	Shell Gadus S5 V100 or Equivalent	Auxiliary terminal box	NA

I<sub>a</sub>/I<sub>N</sub> - Locked Rotor Current / Rated Current

T<sub>b</sub>/T<sub>N</sub> - Breakdown Torque / Rated Torque

T<sub>v</sub>/T<sub>N</sub> - Locked Rotor Torque / Rated Torque

**NOTE**

All performance values at rated voltage and frequency.

All performance parameters are subjected to standard tolerance as per IEC 60034-1

\* Voltage, Frequency and combine variation are as per IEC60034-1

Technical data are subject to change. There may be discrepancies between calculated and name plate values.

Efficiency Standards	Europe	China	India	Aus/Nz	Brazil	Global IEC
	-	-	IS 12615 : 2018	-	-	-

Model No. TCA0223A3131GA CD01

Enclosure	U (V)	Δ/Y Conn	f (Hz)	P (kW)	P (hp)	I (A)	n (RPM)	T (kgm)	T (Nm)	IE Class	Amb Temp (°C)	Duty	Elevation (m)	Inertia (kg·m <sup>2</sup> )	Weight (kg)
TFC	415	Δ	50	22	30	42.0	987	22.07	216.43	IE3	50	S1	1000	0.7703	329

**Motor Load Data**

Load Point	NL	1/4FL	1/2FL	3/4FL	FL	5/4FL
Current	A	19.5	21.5	26.4	33.3	42.0
Torque	Nm	0.0	53.6	107.5	161.8	216.4
Speed	r/min	1000	997	994	991	987
Efficiency	%	0.0	88.2	92.4	92.2	92.2
Power Factor	%	5.0	41.1	60.0	73.0	79.0

**Performance vs Load Chart**

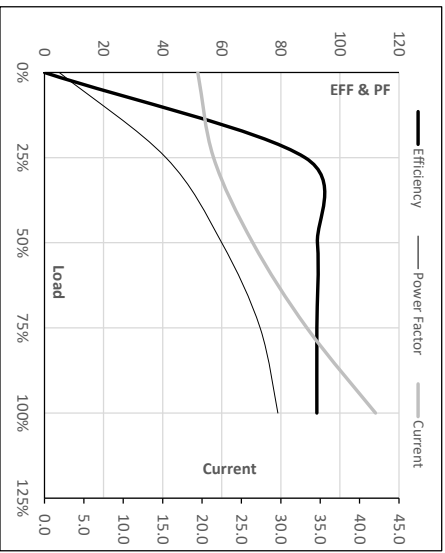

**Motor Speed Torque Data**

Load Point	LR	P-Up	BD	Rated	NL	
Speed	r/min	0	143	908	987	1000
Current	A	298.4	268.5	161.3	42.0	19.5
Torque	pu	2.6	2.1	3.0	1	0

**Starting Characteristics Chart**

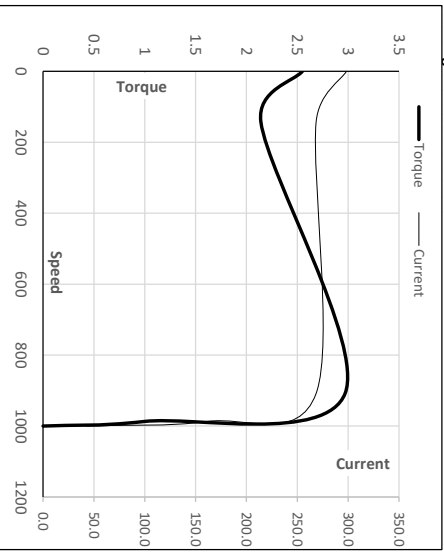

**NOTE** Refer data sheet for applicable standard and tolerances on performance parameters

Issued By  
Issued Date



Model No. TCA0223A3131GACD01

Enclosure	U	$\Delta$ /Y	f	P	P	I	n	T	T	IE	Amb	Duty	Elevation	Inertia	Weight
	(V)	Conn	[Hz]	[kW]	[hp]	[A]	[rpm]	[kgm]	[Nm]	Class	[°C]		[m]	[kg·m <sup>2</sup> ]	[kg]
TEFC	415	$\Delta$	50	22	30	42.0	987	22.05	216.43	IE3	50	S1	1000	0.7703	329

**Motor Speed Torque Data**

Load	FL	I <sub>1</sub>	I <sub>2</sub>	I <sub>3</sub>	I <sub>4</sub>	I <sub>5</sub>	LR	
TWT Hot	s	10000	50	36	30	25	20	15
TWT Cold	s	10000	100	71	60	50	40	30
Current	pu	1	2	3	4	5	5.5	7.1

**Thermal Characteristics Chart**

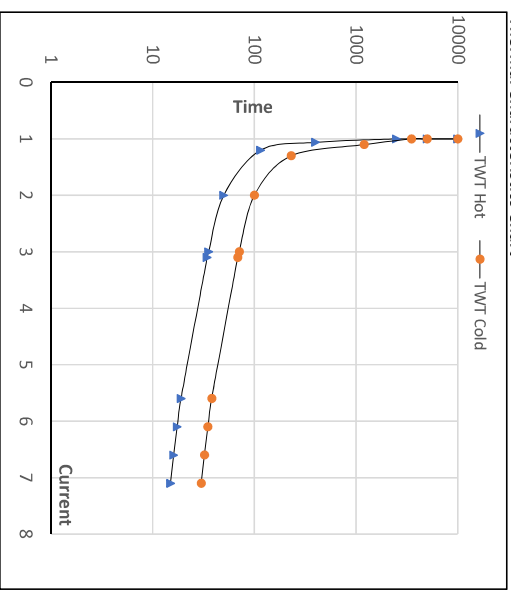

**NOTE** Refer data sheet for applicable standard and tolerances on performance parameters

Issued By  
Issued Date